

# Superformance

## AXLE MEASURING GUIDE

### INVOICING ADDRESS

NAME: .....  
 COMPANY: .....  
 ADDRESS: .....  
 TOWN/SUBURB: .....  
 STATE: ..... POSTCODE: .....  
 PHONE: ..... FAX: .....  
 EMAIL: .....

### DELIVERY ADDRESS

ATTENTION: .....  
 COMPANY: .....  
 ADDRESS: .....  
 TOWN/SUBURB: .....  
 STATE: ..... POSTCODE: .....  
 PHONE: ..... FAX: .....

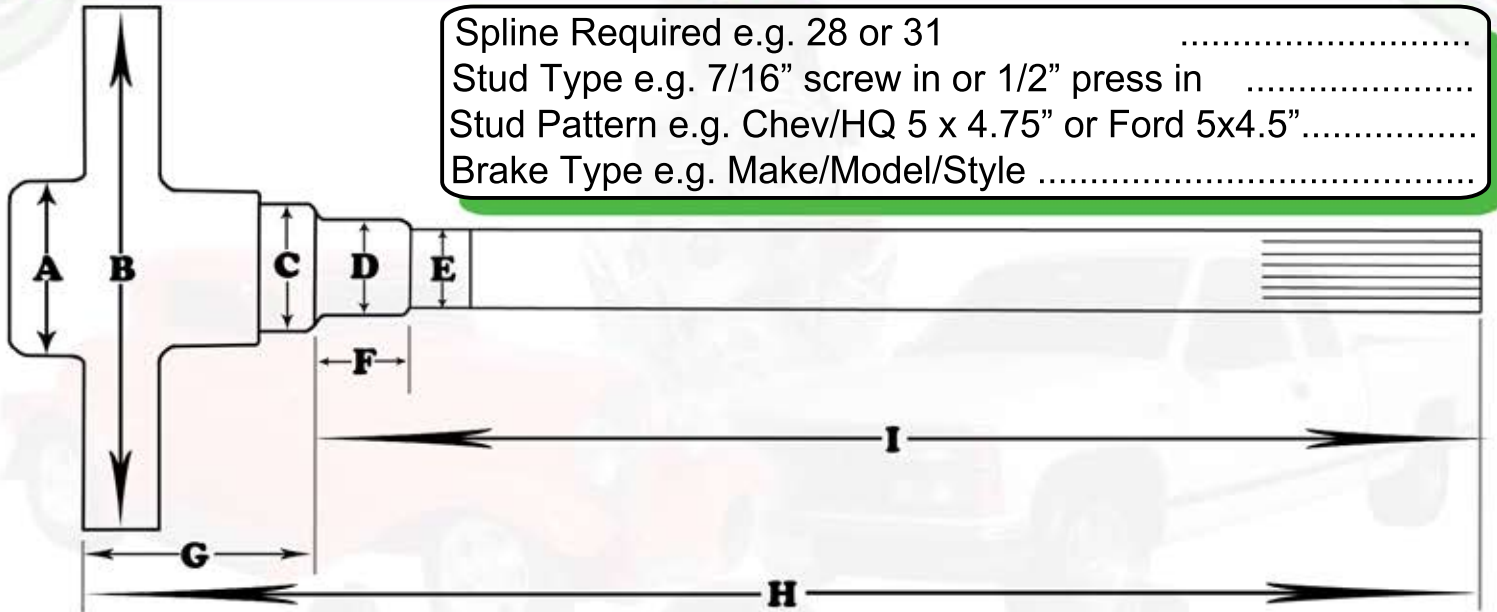

Spline Required e.g. 28 or 31 .....  
 Stud Type e.g. 7/16" screw in or 1/2" press in .....  
 Stud Pattern e.g. Chev/HQ 5 x 4.75" or Ford 5x4.5" .....  
 Brake Type e.g. Make/Model/Style .....

- A - Snout Diameter .....in mm
- B - Flange Diameter .....in mm
- C - Seal Diameter .....in mm
- D - Bearing Journal Diameter .....in mm
- E - Seal Diameter .....in mm
- F - Bearing Journal Width .....in mm
- G - Outside Flange to Bearing Shoulder .....in mm
- H - (**Drivers Side**) Overall Length .....in mm
- H - (**Passenger Side**) Overall Length .....in mm
- I - (**Drivers Side**) End of Seal to End of Axle .....in mm
- I - (**Passenger Side**) End of Seal to End of Axle .....in mm